

VAN DER STÄHL SCIENTIFIC
IMPULSE SEALER

OPL SERIES SPECIFICATIONS

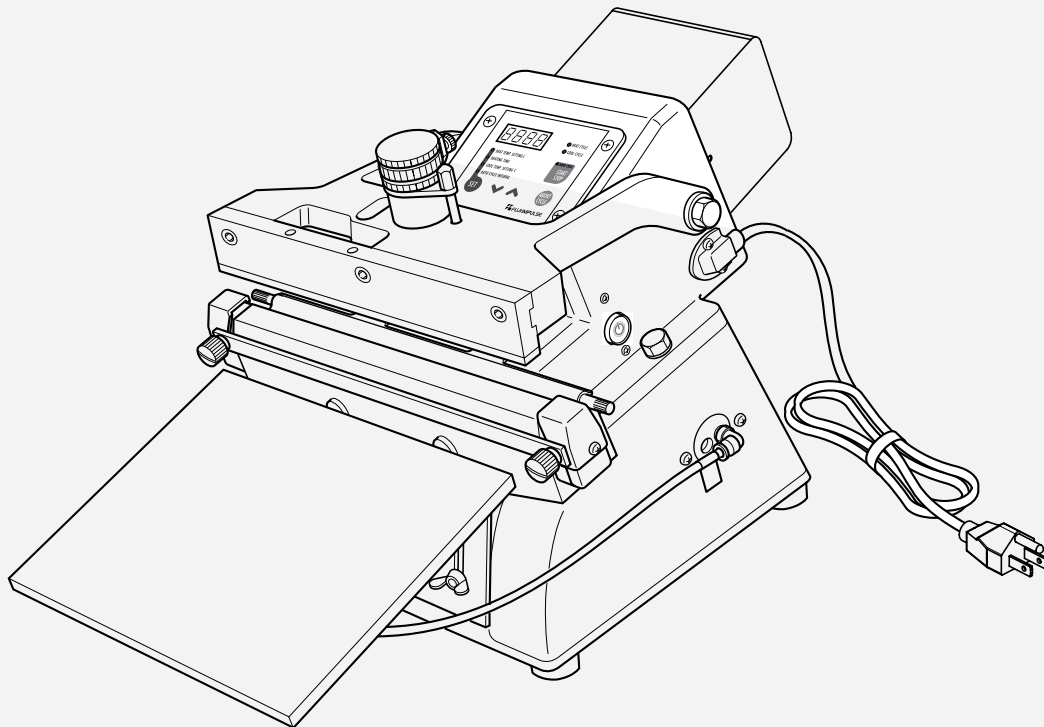

van der stähl[®]
SCIENTIFIC

www.vanderstahl.com



OPL Series

ABOUT

The OPL Series medical pouch sealer has been the leading choice among many medical device companies that seal larger pouches. This microprocessor-controlled pouch sealer manages critical temperature at the sealing platen with a thin-film temperature sensor. This sensor has been designed to mimic the pouch environment and accurately feeds back thermal data to better manage temperature. The sealer creates a wide 10mm seal to create a robust sealed channel between the sterile part and the ambient environment. The sealer also includes a switch table (on 300mm models only) that allows operators to activate the switch with the side of their hands.

Choose from 300mm (11.81") 450mm (17.72") or 600mm (23.62") to accommodate your larger pouch. All parameters are controlled by the same microprocessor as our popular MS 350 pouch sealer. Capable of bonding a wide variety of films such as nylon, Mylar, Tyvek® and even heavy foil films when configured with optional dual heating elements. The sealer is operated by a foot or table switch and can be set in a semiautomatic mode for hands free activation.

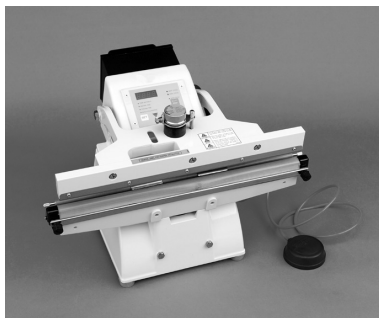



OPL Series

Specifications

- Voltage: AC110/220
- Power Consumption:
 - OPL-300-5: 1,100W/OPL-300-10: 1,500W
 - OPL-450-5: 1,200W/OPL-450-10: 2,200W
 - OPL-600-5: 1,500W/OPL-600-10: 2,700W
- Sealing Dimensions:
 - OPL-300: 5mm/10mm x 300mm
 - OPL-450: 5mm/10mm x 450mm
 - OPL-600: 5mm/10mm x 600mm
- Sealing Method: Impulse / lower single-side heating type
- Heating Temperature: 140°F to 480°F (In 1°F increments)
- Heating Time: 0.0 - 5.0 seconds (In 0.1 second increments)
- Cooling Temperature: From 100°F to the set heating temperature (In 1°F increments)
- Temperature Precision: ±10oF
- Compatible Film Thickness: Less than 0.5mm (total thickness of the overlapping films)
- Machine Dimensions:
 - OPL-300-5/10: 360mm x 580mm x 360/360mm x 590mm x 360mm (With table)
 - OPL-450-5/10: 520mm x 510mm x 360 (With table) /520mm x 380mm x 370mm
 - OPL-600-5/10: 680mm x 390mm x 360mm/680mm x 390mm x 370mm
- Weight:
 - OPL-300-5: 16kg/OPL-300-10: 16.5kg
 - OPL-450-5: 15kg/OPL-450-10: 16kg
 - OPL-600-5: 19kg/OPL-600-10: 23.5kg
- Sealer Operation: By depressing the touch switch/Automatic cycling
- Auto Cycle Interval: 0.1 - 5.0 seconds (In 0.1 second intervals)
- Platen Drive System: Electronic Solenoid



OPL Series

Fast Facts

- Microprocessor controlled temperature with temperature display
- Release temperature control
- Auto sealing/cooling cycles for seal-to-seal consistency
- Unsurpassed and repeatable seal integrity
- Tyvek®/clear film pouches can be sealed face up
- Designed & manufactured for long duty performance
- Cleanroom-friendly design
- Safety Mechanism prevents finger/hand injuries
- Footswitch or auto interval cycling operation
- Equipped with a 10mm or 5mm wide heating element
- Silicone solenoid boot
- 4 digit password option
- Optional printer available (FEP)